

# Village of St Bernard

Department of Buildings & Planning  
 110 Washington Avenue  
 St. Bernard, Ohio 45217  
 (513)-242-7770 Fax (513)-641-1840  
<http://www.cityofstbernard.org>



## Residential Deck Drawings

A permit is required for any deck that is above grade level. This includes decks that have the bottom of the structure on the ground. Plans should include three copies of deck construction drawings and lot plans with the deck shown to scale and the distance to property lines. When applying for a permit to construct a deck, there are a few items that must be submitted for building and zoning compliance. These items need to appear on the drawings submitted with the application form for a permit. They are related to requirements in the 2019 Residential Code of Ohio. A copy of the code is available for reference at <https://www.com.ohio.gov/dlco/BBS> Click "Codes"

The information and details shown on the following sheets can be used as part of your permit plans for your deck. They are available as a guide to help you with the detailing, and they can be used partially or in full. For example, if you have Framing Plans already prepared, then any of the other information such as the Stair Section and one of the Ledger Board Details, can be printed and submitted along with the Framing Plans to complete your set of drawings.

Please call our office if you have any questions or if you need assistance using the drawings. Our drawings are one example and are not the only way to comply for deck permits.

### General Notes

- All lumber shall be pressure treated No. 2 Southern Pine or better.
- All metal fasteners & hangers shall be hot-dipped galvanized steel, stainless steel, G185 galvanized or otherwise compatible with the wood treatment. All bolts shall be 1/2" diameter minimum.
- All beams and top rail splices shall occur at a post or otherwise on adequate bearing.
- All footings shall be cast-in-place concrete with a min. 2500 psi compressive strength.
- Guards are required at all areas where the deck/ porch floor is greater than 30" above grade for a distance of 3 feet measured from edge of deck.
- Required guards shall be 36" tall (min.) and be constructed such that a 4" diameter object will not pass through.
- Guard post spacing shall not exceed 6ft.
- Guards and handrails are required at all stairs that are greater than 30" above grade.
- The deck/ porch floor shall be within 30" of the of the door threshold.
- Live Load Deflection: Joist & Beams – L/360  
Guards – L/240
- Design Loads: Floor Live Load – 40 lbs./ sf (min.)  
Wind Speed – 90 mph (Vult 115 mph)  
Soil Bearing Pressure – 1500 lbs./ sf
- Guards shall be designed for a 200 lb. concentrated load placed along the top of the rail in any direction, at any point.
- This deck/ porch is not designed for hot-tub or spa loading.
- All exterior stairs & associated landings shall be illuminated.
- Post size is based on the height of the deck floor above finished grade (at the highest point):  
0' to 8' high 4x4, 4x6, 6x6  
8' and up: 6x6
- The actual field construction shall match the approved plans. All field changes and/ or deviations require an Engineering Change approval.

### Front Elevation View

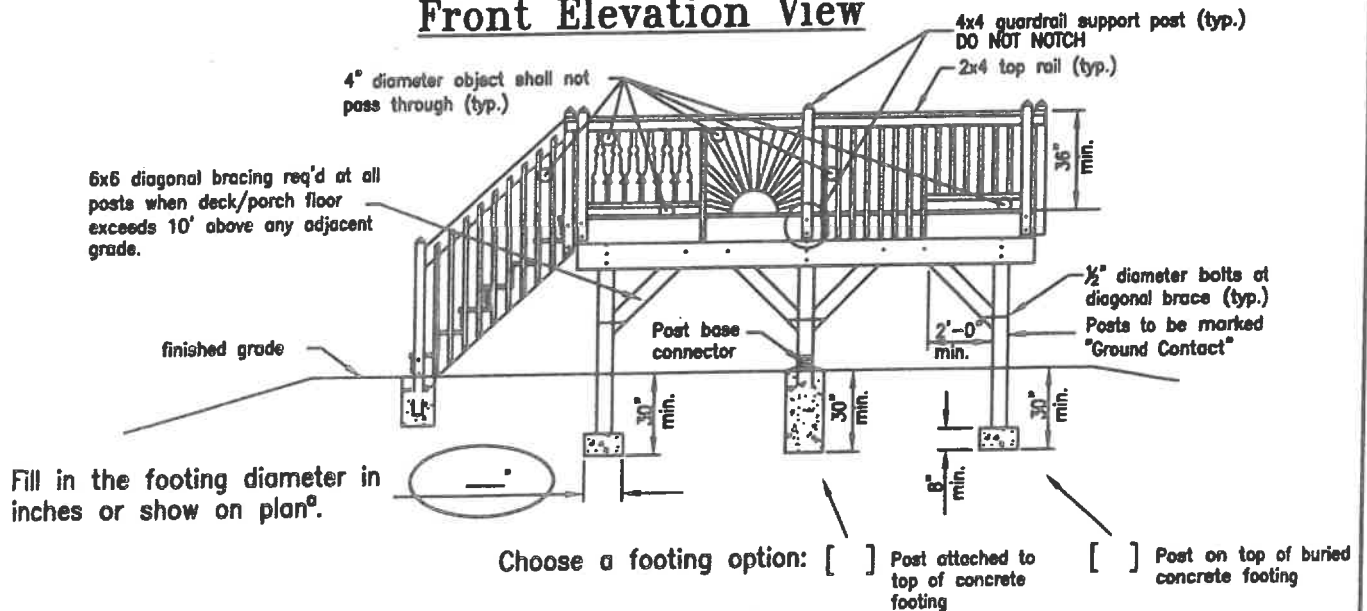

a. The typical footing size is 16" diameter. Smaller diameters may be permitted and larger diameters may be required based on the actual deck framing layout.

Rev. 7/1/2019

Property Address: \_\_\_\_\_

Sheet No.

1 of 4

Application Number: \_\_\_\_\_

Residential Deck Drawings

# Foundation & Framing Plan

Choose a span configuration:

- Single-Span floor joists
- Multi-Span floor joists

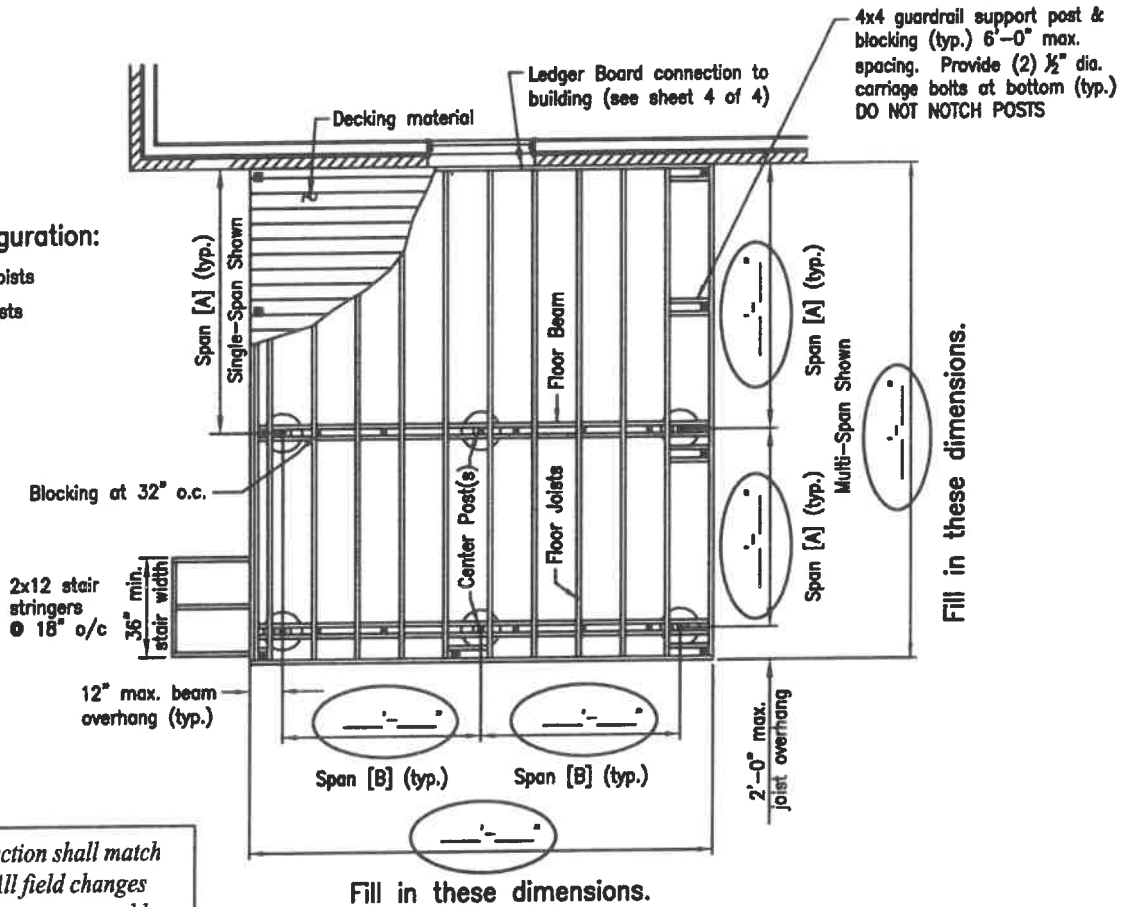

The actual field construction shall match the approved plans. All field changes and/or deviations require an approval by the building department.

## Framing Table

FLOOR JOISTS <sup>1</sup>			FLOOR BEAMS <sup>2</sup>		
CHOOSE JOIST SIZE	LUMBER SIZE (nominal)	MAX. SPAN [A] (feet)	CHOOSE ONE ROW	LUMBER SIZE (nominal)	MAX. SPAN [B] (feet)
[ ]	2 x 6	9'-0"	[ ]	(2) 2 x 6	5'-6"
			[ ]	(2) 2 x 8	7'-0"
			[ ]	(2) 2 x 10	8'-6"
			[ ]	(2) 2 x 12	10'-0"
[ ]	2 x 8	11'-10"	[ ]	(2) 2 x 8	6'-2"
			[ ]	(2) 2 x 10	7'-4"
			[ ]	(2) 2 x 12	8'-7"
[ ]	2 x 10	14'-0"	[ ]	(2) 2 x 10	6'-9"
			[ ]	(2) 2 x 12	8'-0"
[ ]	2 x 12	16'-6"	[ ]	(2) 2 x 12	7'-0"

1. Choose one joist size with the associated maximum span. All joists are spaced a maximum of 16" O.C.
2. Choose one floor beam with the associated maximum span that corresponds with the size of joist chosen.

Application No.

Sheet No.

2 of 4

Rev. 7/1/2019

Residential Deck Drawings

## Left Side Elevation View

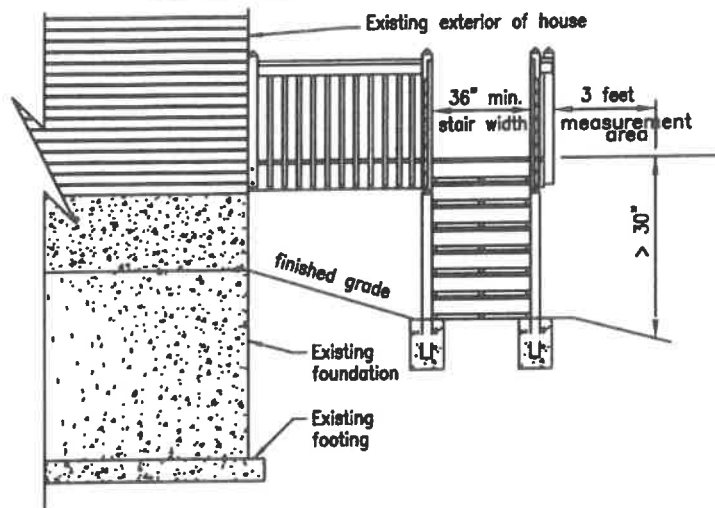

Min. 36" high guardrails required when deck surface is more than 30" above the adjacent grade for a distance measured 3 feet from edge of deck

Fixed Seating shall be guarded Min. 36" high from seat upward

## Stair Section View

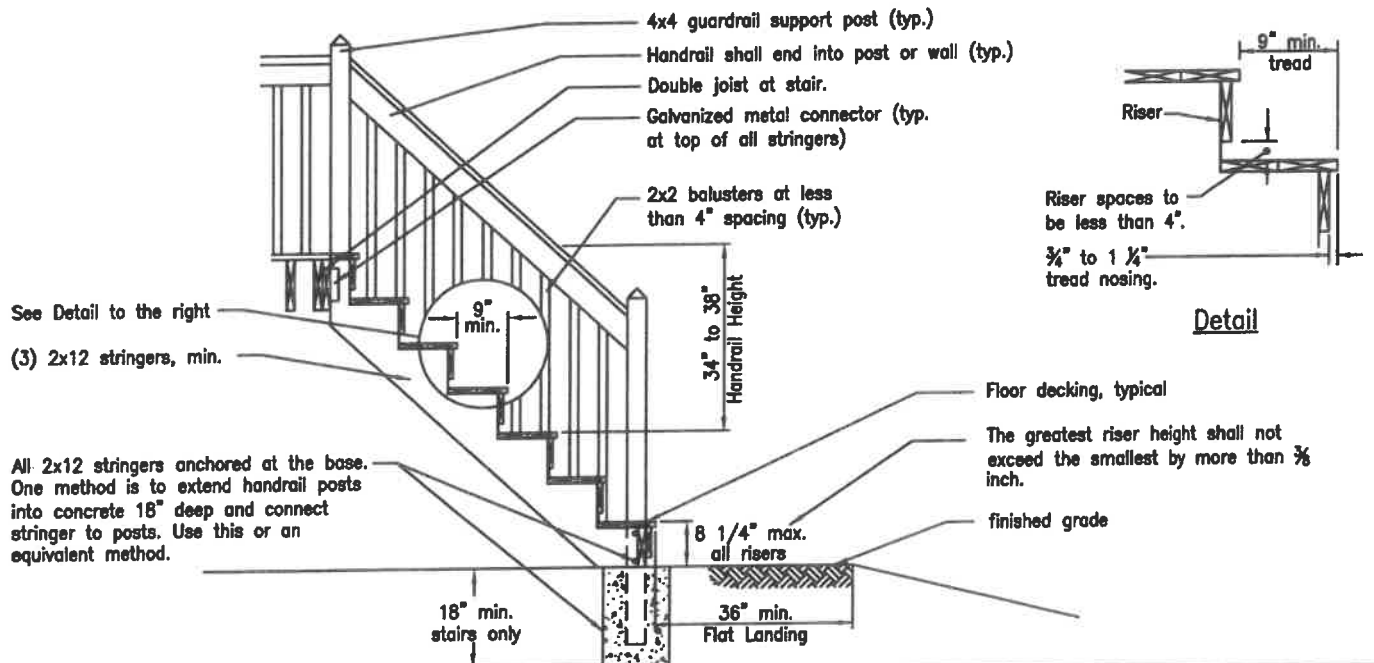

Riser spaces to be less than 4".  
3/4" to 1 1/4" tread nosing.

Detail

## Handrail Sections at Stairs

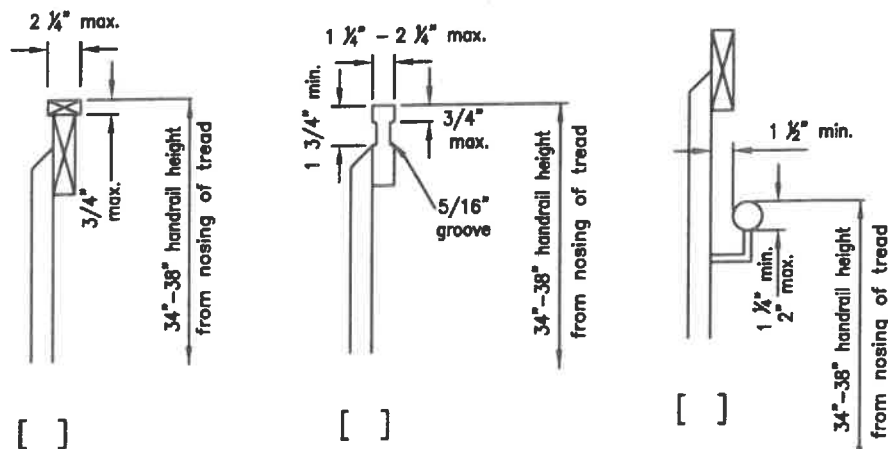

Choose a handrail grip style: [ ]

[ ]

[ ]

[ ]

Application No.

Sheet No.

3 of 4

Residential Deck Drawings

Rev. 7/1/2019

# Beam-to-Post Connection Details

Choose one beam-to-post connection option. Choose one post size based on the height of the deck.

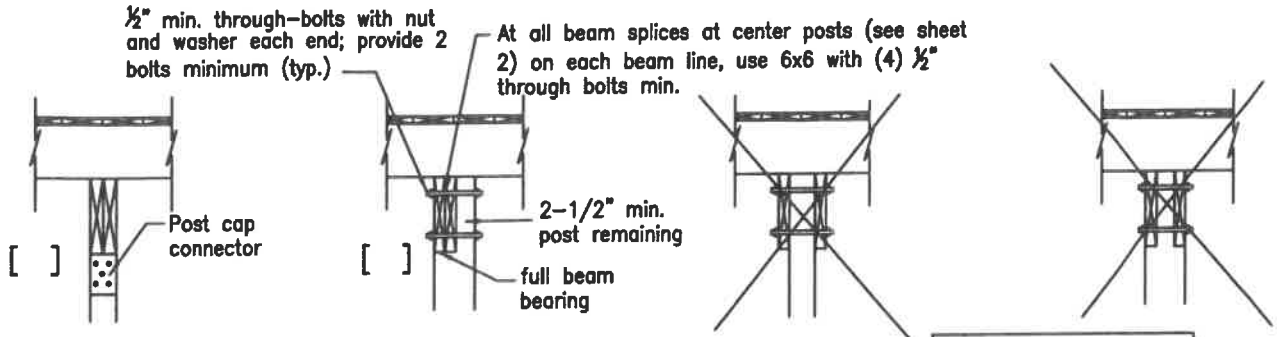

1/2" min. through-bolts with nut and washer each end; provide 2 bolts minimum (typ.)

At all beam splices at center posts (see sheet 2) on each beam line, use 6x6 with (4) 1/2" through bolts min.

Post cap connector

2-1/2" min. post remaining  
full beam bearing

- 4x4 posts required up to 8'
- 4x6 posts (up to 8')
- 6x6 posts (req'd over 8')
- 6x6 posts (req'd over 8')
- (6x6 posts required at beam splices)
- (6x6 posts required at beam splices)

Details no longer permitted as of July 2019  
"Direct Bearing" required

# Ledger Board Details

Choose the ledger board detail that applies.

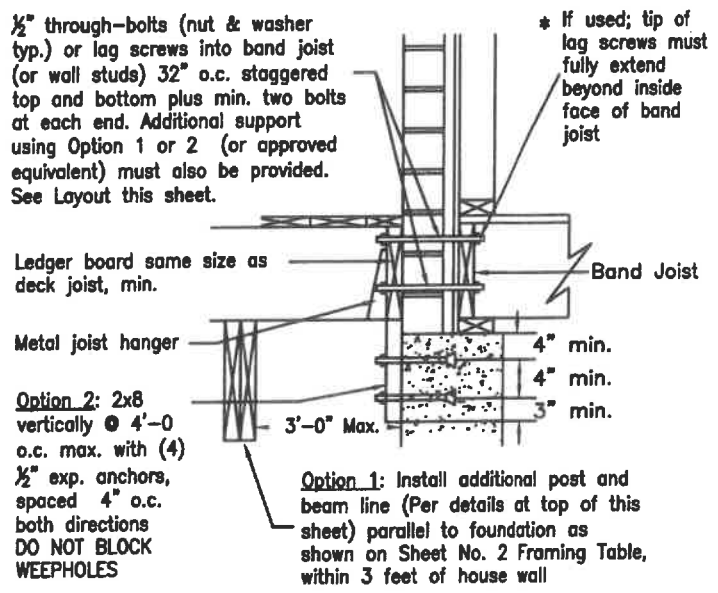
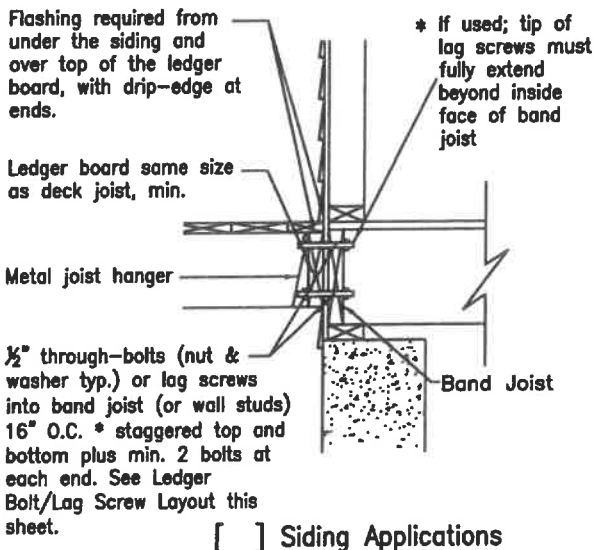

\* 1/2" Lag screws with 16" O.C spacing can be used for 10 feet max. joist spans. For longer joist spans, the maximum spacing shall be as follows in the joist span table below.

* Joist Span/Lag Screw Fastener Spacing			
10'-1" to 12'	12'-1" to 14'	14'-1" to 16'	16'-1" to 18'
15"	13"	11"	10"

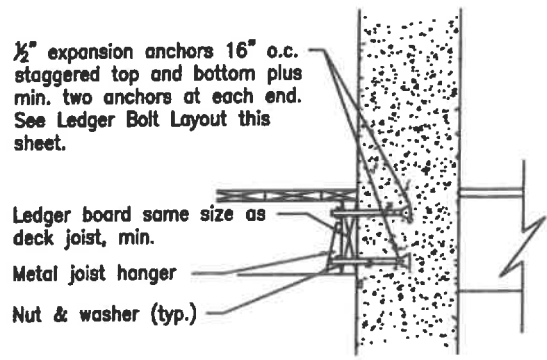
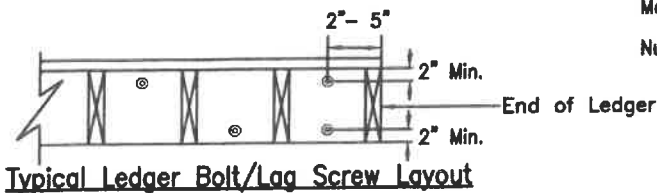

Application No.  
Sheet No.  
4 of 4  
Residential Deck Drawings